



01302 727182 | sales@underfloorheating1.co.uk

INSTALLATION GUIDE



Details correct as of January 2026

Contents

Pre-Installation Check List for Screed & Joisted Floors	3
Before you Start - Recommendations for all installs.....	4
Floor Constructions for Screed Floors and Templates	5
Joisted Floor Biscuit Mix & Cross Battening.....	6
Joisted Floor Using Aluminium Spreaders & Variotherm Retrofit.....	7
Installation of Manifold.....	8
Toplo Mixing Valve / pump pack information.....	9
Toplo Mixing Valve / pump pack information (Continued).....	10
Installation of pipe	11
Filling & Pressurising the system.....	12
Filling & Pressurising the system (Continued)	13
Filling & Pressurising the system (Continued)	14
Commissioning and Trouble Shooting.....	15
Underfloor Heating Maintenance	16
Underfloor Heating Maintenance (Continued).....	17
Underfloor Heating Maintenance (Continued).....	18
Underfloor Heating Electrical Schematic Option 1	19
Underfloor Heating Electrical Schematic Option 2	20
Wifi Digital Heating Thermostat manual	21
Wifi Digital Heating Thermostat manual (Continued)	22
Wifi Digital Heating Thermostat manual (Continued)	23
Wifi Digital Heating Thermostat manual (Continued)	24
Wifi Digital Heating Thermostat manual (Continued)	25
Toplo Wifi Stat Mobile App Programming Guide	26
Toplo Wifi Stat Mobile App Programming Guide (Continued).....	27
Toplo Wifi Stat Mobile App Programming Guide (Continued).....	28
Toplo Wifi Stat Mobile App Programming Guide (Continued).....	29

PRE-INSTALLATION CHECKLIST

SOLID / SCREED FLOORS

1. Insulation fitted neatly and stable with all gaps and joints taped.
2. If using liquid screed, a membrane of between 500 and 1000 gauge must be laid as crease / fold free as possible with all joints taped and no gaps. The membrane should lap up the wall by approx 100mm - paying attention to corners and joins will give a neater edge to the screed.
3. If pipe is to be routed through walls, there should be a suitably sized hole(s) for this with conduit around the pipe to protect it.
4. Perimeter insulation should be fitted around all walls (also over the 500 gauge membrane if applicable). Pull the plastic skirt out and if using liquid screen, tape the skirt to the membrane along all edges, see picture.



JOISTED FLOORS

1. Insulation fitted neatly in between joists
2. If pipe is to be routed through walls, there should be a suitably sized hole for this.
3. Notching of the joists as per building and insurance regulation

RECOMMENDED FOR ALL INSTALLATIONS

1. A mains water supply with a suitable tap connection (Hozelock or bib tap etc) should be available within 20m of the manifold(s)
2. A solid provision for the manifold(s) to be fitted to should be available
3. All areas free of other trades, water and debris etc
4. Electricity supply for power tools and lighting
5. Our CAD design (if applicable) should be approved before the installation date

EQUIPMENT / DESIGN

1. Before commencing with installing materials check the equipment is complete, correct, undamaged and matches the delivery note / invoice Check that the CAD design (if applicable) is present and correct to your property etc.

Check you have the appropriate fixings for the floor construction

The installation of this equipment should be carried out by a competent person and in accordance with the relevant, Building Regulations, Model Water By laws and the Building Standards (Scotland) Regulations.

Underfloorheating1 shall not be responsible for any damage or loss resulting from failure to carefully observe the instructions given. Installers should read this manual carefully. Responsibility for finished system function and operation rests with the installer. Please pay attention to the following points.

1. Please check you have been delivered all components to complete installation in accordance with these instructions. If you have any doubts please call the Underfloorheating1 despatch department on 01302 727182. All queries must be notified within 48 hours of delivery or subsequent items may be charged.
2. Where pipes pass through walls they must be sleeved with flexible conduit.
3. The CAD drawing supplied contains information on pipe spacing and pipe lengths, this must be observed.
4. Please ensure all timber joist notching complies with building regulations and the building insurers.
5. The software use for the CAD design calculates the total amount of pipe required to complete the installation. The system allows for 5 metres per circuit contingency. Please make sure you optimise pipe supplied by calculating (or read the pipe schedule), before cutting, the optimum lengths required to be cut from each particular roll. Underfloor Heating 1 accept no responsibility for pipe shortages as a result of mistakes of failure to optimise pipe cutting.
6. Make sure you understand the design and pay careful attention to pipe spacing.

FLOOR CONSTRUCTIONS

Screed Floor

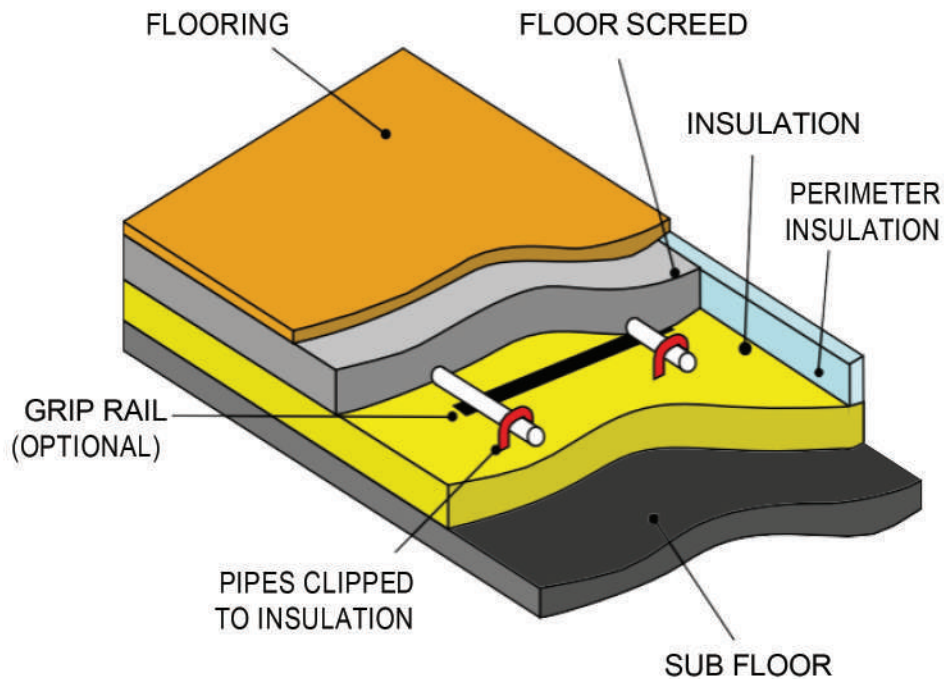

- ◆ Insulation - refer to building regulations for size.
- ◆ Screed - We recommend 50 - 75mm liquid or 65 - 75mm traditional screed
- ◆ Seek building control advice on the position and use of damp proof membrane
- ◆ 500 gauge screed membrane above the insulation before pipe is required for liquid screed

Screed Floor (with floor templates)

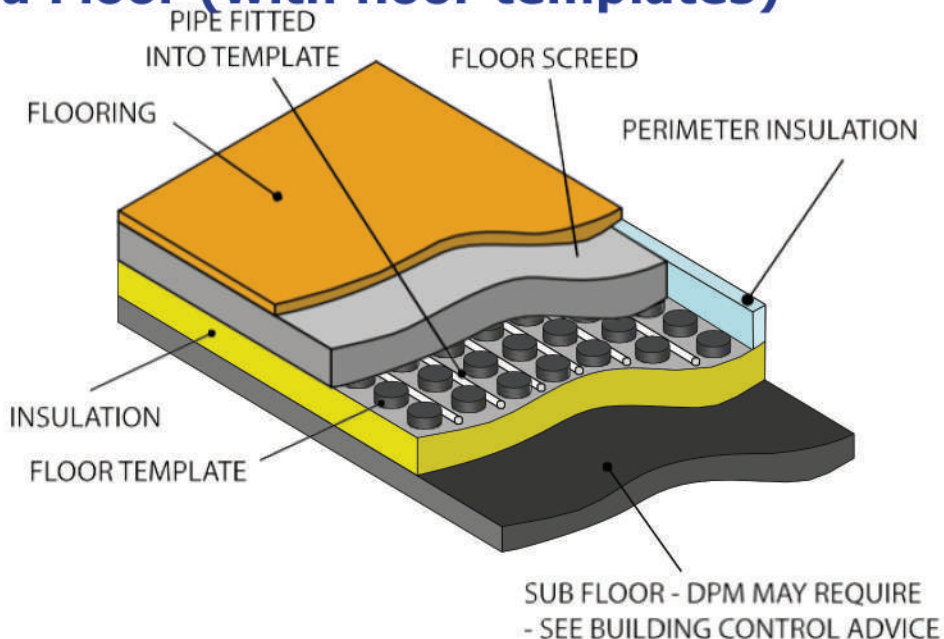

- ◆ Insulation - refer to building regulations for size.
- ◆ Screed - We recommend 65 - 75mm traditional screed
- ◆ Seek building control advice on the position and use of damp proof membrane

Joisted Floor (using 'biscuit mix')

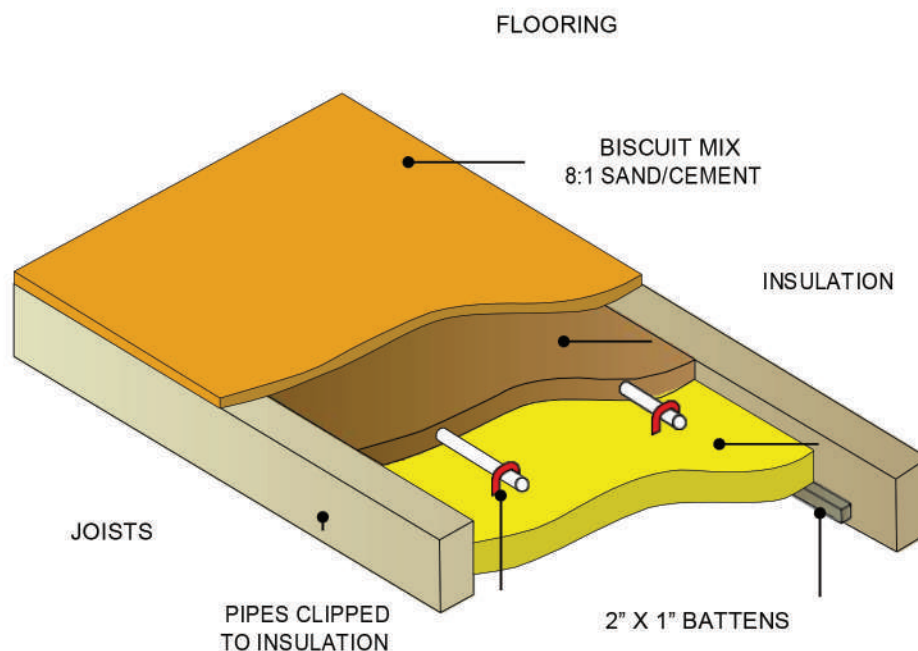

- ◆ Insulation - refer to building regulations for size.
- ◆ Flooring - Plywood/chipboard flooring may be required before floor covering. Contact us if unsure
- ◆ Biscuit Mix - we recommend 20 - 25mm thickness

Joisted Floor (Cross Battening)

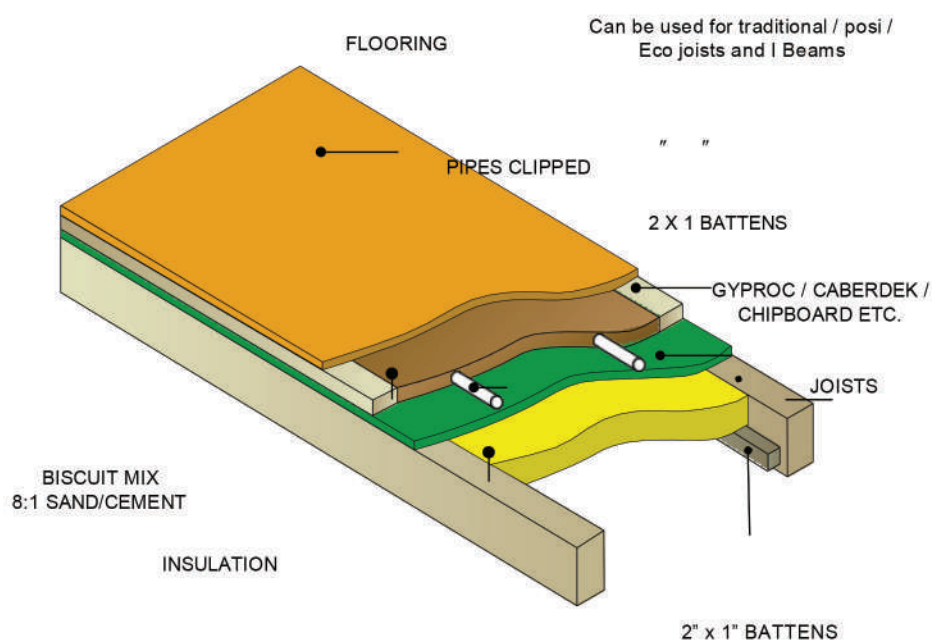

- ◆ Insulation - refer to building regulations for size.
- ◆ Flooring - Plywood/chipboard flooring may be required before floor covering. Contact us if unsure

Joisted Floor (using aluminium spreader plates)

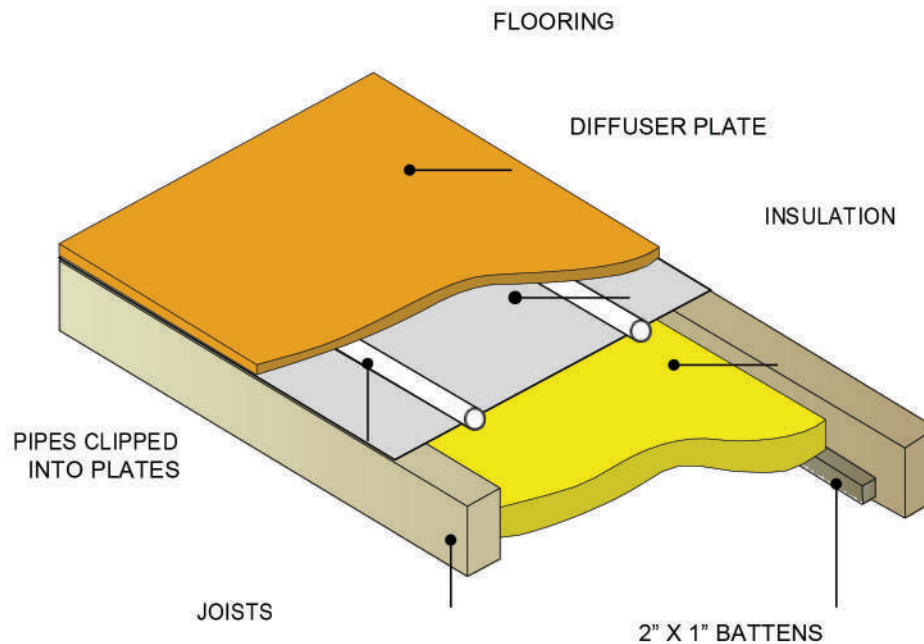

- ◆ Insulation - refer to building regulations for size.
- ◆ Flooring - Plywood/chipboard flooring may be required before floor covering. Contact us if unsure

Variotherm Compact Floor Retrofit system

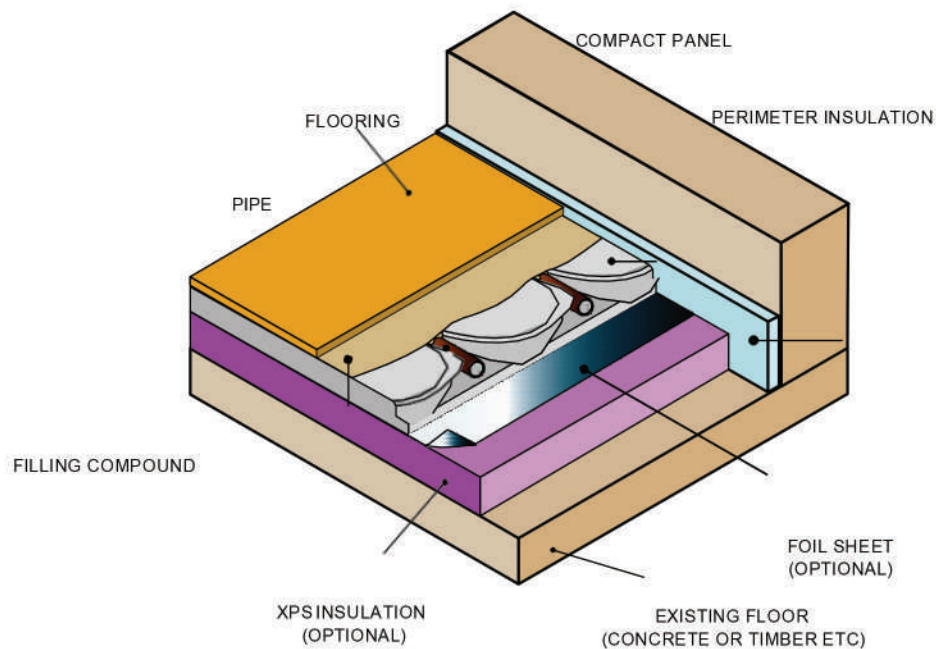

VARIOTHERM

INSTALLATION OF MANIFOLD

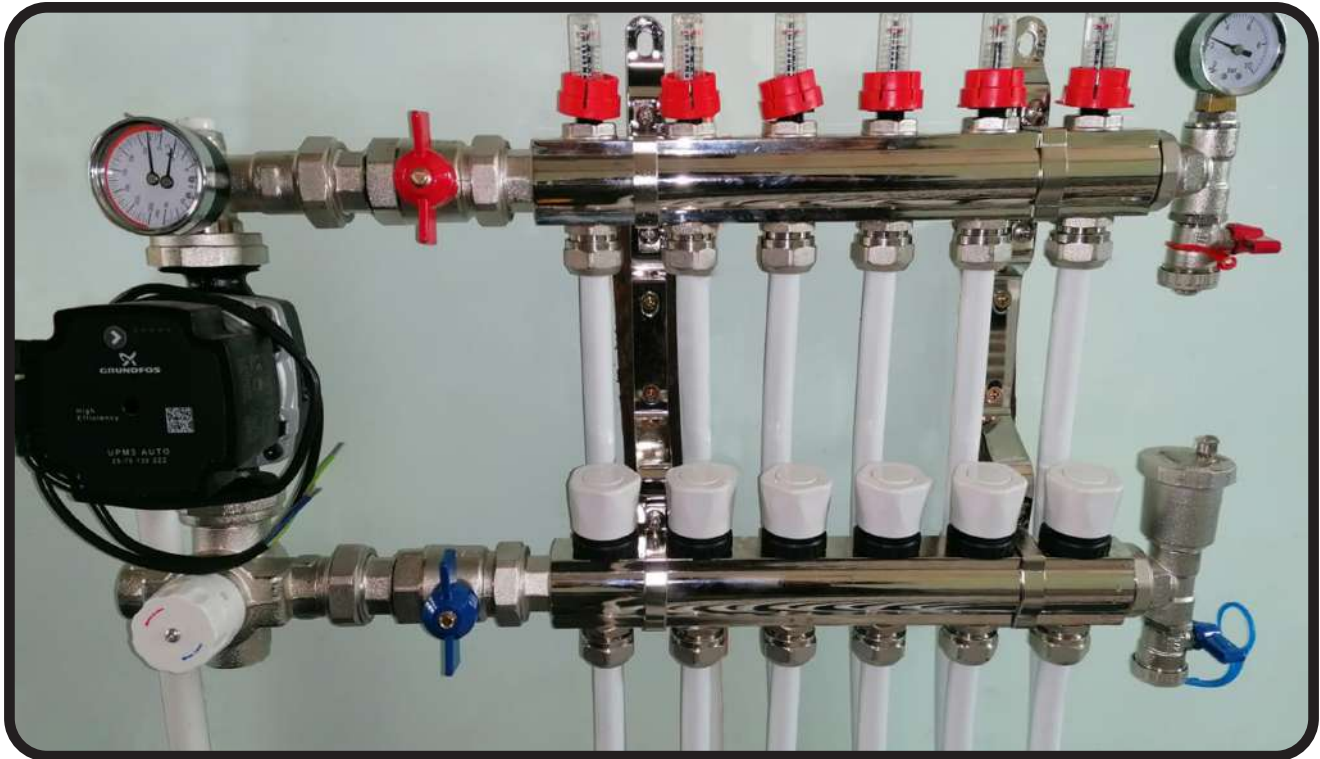

The manifold should be installed with the top rail of the manifold approximately 600mm from the floor. It should be securely fixed to a solid mounting point such as brick/blockwork etc. Modern UFH pumps are very quiet however we do not recommend installing the manifold on a timber stud wall due to noise transfer.

Although UFH systems are mostly maintenance free, there should be room around the manifold to access it.

The manifold is reversible so flow/return pipework can be at either side. If using the 'easy fit pump pack' (example pictured) see the item instructions for mounting it correctly.

ALTERNATIVE PUMP INSTALLATION



pump/blending valve can be mounted LH or RH as shown

Toplo mixing valve / pump pack information

LH / RH manifold mounting

The mixing valve/pump set can be mounted on either the left or right hand side of the manifold. The components come as standard to fit on the left hand side.

To mount to the right hand side, firstly remove the brackets from the manifold and spin the manifold rails around so that isolation valves are on the right and then replace the mounting brackets. Fix the manifold to the wall before attaching the mixing/valve pump set (it's easier this way)



Take the mixing valve part of the set and remove the male threaded part as shown



Using the brass hex tool, remove the part from the mixing valve as shown. You may need another pair of grips to hold the body of the mixing valve. There are flats on the body to grip, be careful not to damage any part.



Fit this part into the other side of the mixing valve and tighten using the brass hex tool

- Take the upper part (gauge housing) of the set and remove the temperature/pressure gauge (by hand)
- Remove the 10mm fitting from the other side and refit the temperature/pressure gauge here, refit the 10mm fitting where the temperature/pressure gauge was originally
- Fit the pump to the mixing valve ensuring the rubber O ring is in between, leave the nut slightly loose and ensuring the arrow on the casing is facing upwards
- Fit the upper part ensuring the rubber O ring is in between, leave the nut slightly loose
- Fit the two male thread connections to the manifold, we strongly recommend the use of PTFE tape or liquid despite there being a seal on this fitting.
- Fit the mixing valve/pump set to the manifold connections, tightening all of the joints by hand first
- Tighten all joints using correct spanners/adjustable wrenches

Elbow / joints to the manifold

We strongly recommend the use of PTFE tape or liquid on the elbow fitting, pipe connections and connections to the manifold (even where there is a seal). The elbow joint is an optional use fitting and it can be used on either the flow or return side of the mixing valve to assist with pipe connections.

Heating connections

The heating system should be connected with the flow in to the bottom connection and the return out of the side (irrespective of RH or LH mounting)



The female connections are 3/4" BSP and fittings are widely available for 22mm and 28mm copper. These are often referred to as 'male/iron' or 'number 3' fittings. Please refer to our technical details in this document for the correct pipe size to use.

Flow & return pipe work

Most UFH systems require 1.5-2.5 litres/min flow per circuit and therefore the supply pipework to the manifold (flow and return) should be sized by the heating system engineer/installer with lengths of pipe, bends and resistance calculated to cater for the total demand of the manifold. E.g. a 7 port manifold would require 10.5-17.5 l/min if all circuits are being used. The table below is a **guide only for boiler based systems** and we will not accept any responsibility for calculations of flow and return pipe. We recommend that heat pump flow & return pipe work is 28mm minimum but the heat pump installer may be best to advise on this.

Number of UFH circuits	Flow and return distance	Minimum pipe diameter
2 to 7	<14m	22mm
2 to 7	>14m	28mm
8 to 10	<4m	22mm
8 to 10	>4m	28mm
11 to 12	<15m	28mm

Isolation valves & drain off

We recommend that isolation valves are fitted to the flow and return of the mixing valve so that the UFH can be worked on without the need to drain down boilers etc.

We recommend that a drain off is fitted on the flow pipe to the mixing valve so that the pipework can be vented at initial commissioning and/or if any work is done on the overall boiler/heating system.

INSTALLATION OF PIPE

We supply pipe in rolls up to 500m in length. The pipe is marked in 1m increments.

The pipe should always be cut cleanly and straight using a pipe cutter, do not use a saw of any type. If installing in a screed floor, slide 300mm of conduit over the pipe if using screed (as per the above picture). The pipe connector is in 3 parts - nut, olive, nipple - fit the nut over the pipe and then the brass olive. Insert the nipple into the end of the pipe.

Starting at one end of the manifold, push the pipe to the port on the flow rail (red) and connect the nut. Keep pushing the pipe squarely into the port whilst tightening the nut, using a suitable grips or spanner - do not over tighten. Fit the pipe in accordance with the design (if applicable) making note of the pipe used as you lay it - as a rule of thumb we recommend not laying any single circuit more than 100m. We allow in our specifications for 2 clips per metre although more may be required if using low grade insulation such as EPS etc. Connect the other end of the pipe to the corresponding port on the return rail (blue). Repeat the process (as per CAD design if applicable) until all ports have been installed and connected to the manifold.

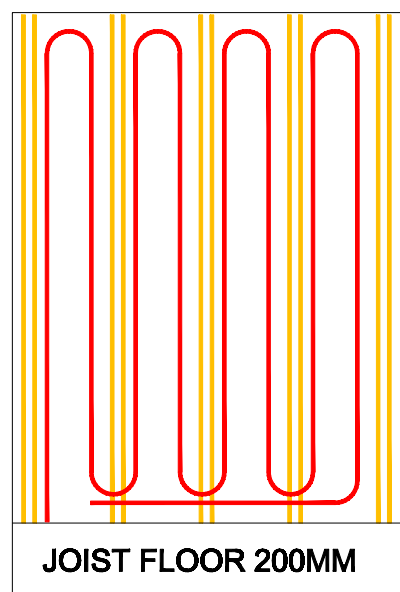
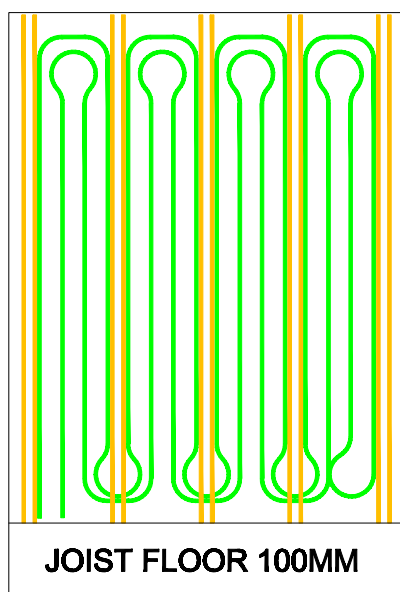
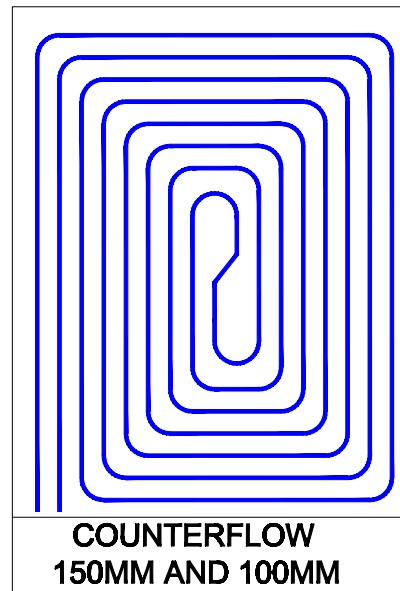
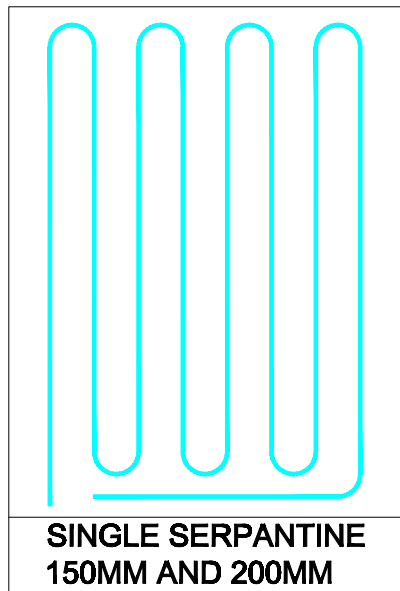

FILLING & PRESSURISING THE UFH SYSTEM

A test is performed at a pressure of 6 bar before flooring, screed or biscuit mix is laid to check for leaks and ensure the pipes are at their most expanded. This pressure is to be maintained until screed application is completed in order to ensure that any leaks are identified immediately and prevent the screed cracking later. 6 bar is a lot higher than a system would normally run.

REMEMBER: You must be extremely careful to avoid frost unless anti freeze has been added to the water.

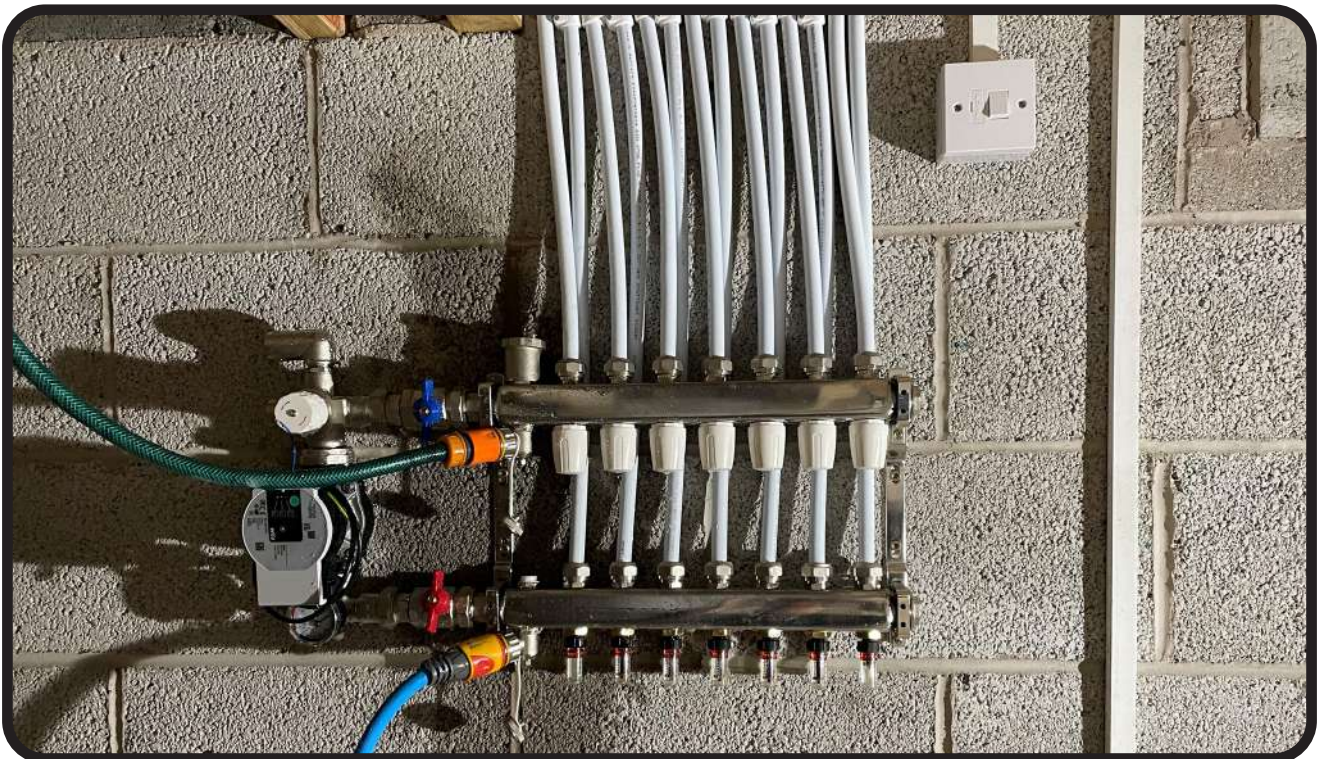

This picture shows how to connect the hose pipes to the manifold.

The flow from the mains tap to the filling point on the flow rail (red) of the manifold and the return / waste hose connected from the drain point of the return manifold (blue) to somewhere the return water can drain to.

Handy tip - putting the return hose into a bucket of water (that can overflow somewhere!) makes it easier to see any air bubbles

FILLING & PRESSURISING THE UFH SYSTEM

1. Close the isolating valves on the manifold (red and blue 'butterflies').
2. Connect suitable filling pipes to the fill and drain points on the relevant rail as per Figure 1.
3. Route the pipe connected to drain point on return rail of the manifold to a suitable discharge spot - secure the open end as it can whip about!
4. Connect pipe from the fill point on the flow rail of the manifold to a mains cold water supply.
5. All the caps (white or blue) on the return rail should be closed. They can be closed by turning them clockwise.
6. All flow meter valves (flow rail) should be closed. They can be closed by turning them clockwise.

See picture below:



Flow meter open (collar removed)

7. Open the first cap on the return rail (at one end) fully by turning anti-clockwise.
8. Open the flow meter valve above the cap opened (i.e. on the same circuit) as per Figure 2.
9. Open the filling and drain points (either a square key beneath the drain point or a small red/blue lever) fully by turning anti-clockwise or quarter turn if the small red/blue lever.
10. Turn on the mains cold water supply.
11. You should see the red indicator marker in the flow meter move to the bottom of the tube. This indicates correct flow of the water in and shows there isn't a blockage. The return hose will probably spit and will have an intermittent flow until the circuit has been purged of all air correctly.

12. When circuit is full and correctly purged, the flow from the return hose will be smooth. Open the next white cap and corresponding flow meter and close the circuit you've done by turning the white cap clockwise as far as it will go. The flow of water should stop immediately, if not, there is still air left in the pipe.
13. Repeat for the next circuit on manifold until all circuits are filled and vented.
14. Once all circuits are filled and vented individually, open all the white caps so that water is flowing through all circuits.
15. Close the drain valve on the return rail drain point and let pressure build for a minute before closing the valve on flow rail fill point.
16. Using a Rothenberger pump or similar (Figure 3), 'pump' the system up to 5 bar via the flow rail filling point (with the point open!) and then close the system off. Leave for 10 minutes. After this time pressure should have dropped by no more than 1 or 2 bar. If pressure drops significantly, check system for leaks and make sure all connections are tight but not over tightened.

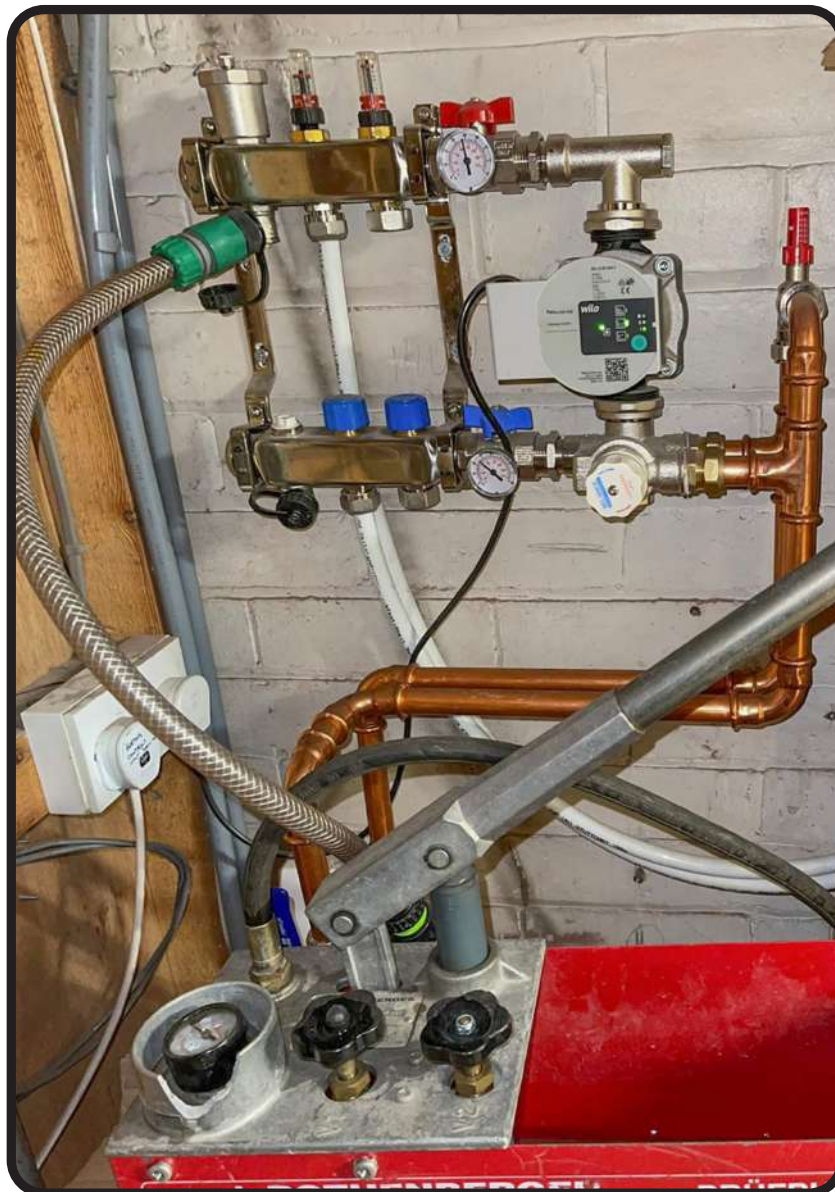

Figure 3 - using a test pump to pressurise the system to 5 bar

COMMISSIONING

Check with screeding company (if applicable) the initial drying/warming up process

Ensure that supply pipe work to the manifold is vented of all air before opening manifold isolation valves and before the rest of the commissioning process

1. Check that all flow meters are open. Turn them anti-clockwise a couple of turns from closed.
2. Switch the programmer for zone 1 so that it is calling for heat, you should see a flame signal.
3. There should be no actuators fitted on the manifold, the manifold pump should run and the zone valve should open (if one is fitted).
4. The boiler should fire up at this stage and the system should circulate water. Turn the flow meter on all circuits until the plastic indicator is around 1.5 (if using a boiler) or 1 for heat pump systems. The flow meter scale works down, so allowing more flow (like opening a tap) moves the red indicator down. As each are adjusted, some you may have already set may alter slightly. We find that it's best to alter in small increments.
5. Turn the zone 1 room stat up to it's highest temperature.
6. Within 5 minutes (some can take that long) the actuator should open there will be an indicator of sorts, usually either a viewing window with plastic indicator, plastic pin moves out of the top or a light within the unit.
7. Fit the actuator(s) to the appropriate valve(s) on the manifold (on large floor areas there may be more than 1 actuator, check the CAD).
8. Now turn off zone one and activate zone two. It is important to work methodically like this to ensure that the correct room stat is operating the appropriate actuator(s).
9. Repeat process until all actuators are checked.
10. Check system pressure is @ 1.5 bar & no further air is coming out of air vents.
11. Check that the temperature on the flow gauge reaches the required temperature - usually 50C for a screed floor and 55 - 60C for a suspended timber floor.
12. Remember for a screed floor the initial heat up period can be up to 8 hours
13. We recommend adding a suitable inhibitor to protect your system – consult with your heat source manufacturer

TROUBLE SHOOTING

SYMPTOMS	CHECKS/REMEDIES
Flow pipe gets hot, return stays cool, even after many hours running, temperature on flow side not increasing.	Insufficient flow from boiler to manifold turn up speed of boiler or manifold pump.
Flow & Return pipes both hot, but temperature on floor low.	Flow & return to manifold wrong way round or manifold pump not running.
No rooms getting hot	Check flow meters (red indicator) have a flow running through and check all valves are open.
Room stat calling for heat, but no power to the pump.	Safety stat on the manifold locked out or faulty, electrical connection problems.
One room warm, other cold.	Check correct thermal heads on correct manifold ports.
One room not getting warm.	Air lock - flush through by repeating the filling up process.
Noise in system.	Manifold fitted on stub partition, acting like sound box. Tension on copper flow & return pipes. Air in system - due to wrong filling procedure
Room gets too warm.	No thermostatic control. Not connected to correct manifold port. Thermal head faulty/ broken. Room stat faulty/broken.

Underfloor Heating Maintenance

Description: Underfloor heating maintenance made simple with UFH1. Learn how to improve efficiency, prevent breakdowns, and keep your home warm and comfortable all year round.

Underfloor heating is one of the most comfortable and efficient ways to heat a home, but only when it's properly looked after. Many homeowners assume these systems are "fit and forget," yet a lack of basic underfloor heating maintenance is one of the main reasons systems fail just as winter arrives.

This guide explains exactly why your system still needs attention during the warmer months, how to keep it running smoothly year-round, and the simple checks that prevent costly breakdowns when you need heat the most.

Part 1 - Why Not Turn It "Off"?

Why Underfloor Heating Maintenance Should Continue in Summer

When we reach the summer months and the temperature rises, turning your [underfloor heating](#) off is a fairly obvious thing to do. But turning off your underfloor heating system completely over the summer can lead to future problems months down the road.

To be clear: **Nobody is suggesting you heat your home in July.**

The advice isn't to keep the heating running at high temperatures, but rather to keep the *system active*. Unlike [electric underfloor heating](#) (which can be turned off without issue), water-based systems rely on mechanical parts and fluid circulation.

Here is why a complete shutdown is dangerous for the health of your system:

1. Preventing the "Seize-Up"

The most common issue with wet systems in autumn is the failure of the circulation pump or the zone valves.

- **The Problem:** Water contains minerals and sediment (sludge). When the water sits stagnant in the pipes for 4–5 months, this sediment settles, and limescale can build up around the moving parts of the [pump and valves](#).
- **The Result:** When you finally turn the thermostat up in winter, the parts are stuck fast. The motor tries to spin, fails, and potentially burns out.

2. Maintaining Seal Integrity

Gaskets and seals within the [manifold](#) (the central hub where the pipes connect) rely on a certain amount of moisture and pressure to remain effective. Leaving a system entirely dormant can sometimes cause seals to dry out or shrink slightly, leading to leaks when the pressure returns in winter.

3. The Solution: The "Summer Cycle"

You do not need to heat the floors. You simply need to **circulate the water**. Turn your heating on for 10 to 15 minutes once a month during the summer. This flushes the water through the valves and keeps the pump spinning freely.

Part 2: The Maintenance Checklist

While underfloor heating is generally low-maintenance compared to radiators, it is not "no-maintenance." The summer is the perfect time to perform these checks so you aren't waiting for a plumber during the winter rush.

1. Check the Pressure

Just like a boiler, your [underfloor system needs pressure](#) to move water.

- Locate the pressure gauge on your manifold.
- It should generally read between **1.0 and 2.0 bar**
- If it is too low, you may need to use the filling loop to top up the water levels. If the pressure drops frequently, you have a leak.

2. The Visual Manifold Check

The manifold is the heart of the system. Take a look at it (usually hidden in a cupboard):

- **Leaks:** Look for any signs of water, damp patches, or corrosion (white/green crusty powder) around the valves.
- **Flow Meters:** Check the glass tubes (flow meters) on the manifold. If they look dirty or discoloured, the water in your system might be "sludgy."

3. Bleeding the System

If you noticed cold spots in the floor last winter or hear gurgling noises, there is air in the pipes.

- Most manifolds have air bleed valves (similar to radiators)
- Open the valve slightly to release trapped air until water starts to trickle out, then close it firmly.

4. System Flushing (The Pro Job)

Over time, iron oxide (rust) and sludge build up in the plastic pipes. This makes the system inefficient, meaning it costs more to heat your home.

- **Recommendation:** Every 3 to 5 years, have a professional perform a **Power Flush**. This forces high-velocity water and cleaning chemicals through the pipes to clear the sludge.

5. Check Your Controls

It sounds simple, but it is often overlooked.

- Replace the batteries in your wireless thermostats.
- Check that the time and date settings are correct (power cuts can reset these).
- Ensure the "setback" temperatures (the minimum temperature the house drops to) are appropriate for the season.

Summary: Underfloor Heating Maintenance: Key Takeaways for a Warm, Efficient Home

Treat your underfloor heating like a car. Even if you aren't driving it cross-country, you still need to start the engine occasionally to make sure the battery doesn't die and the oil circulates.

The Golden Rules:

1. **Do not** let the water sit stagnant for 6 months.
2. **Do** enable "pump exercise" modes or run the system briefly once a month.
3. **Do** check your pressure gauge before the winter cold sets in.

By spending just twenty minutes per month on maintenance, you could prevent future issues.

OPTION 1

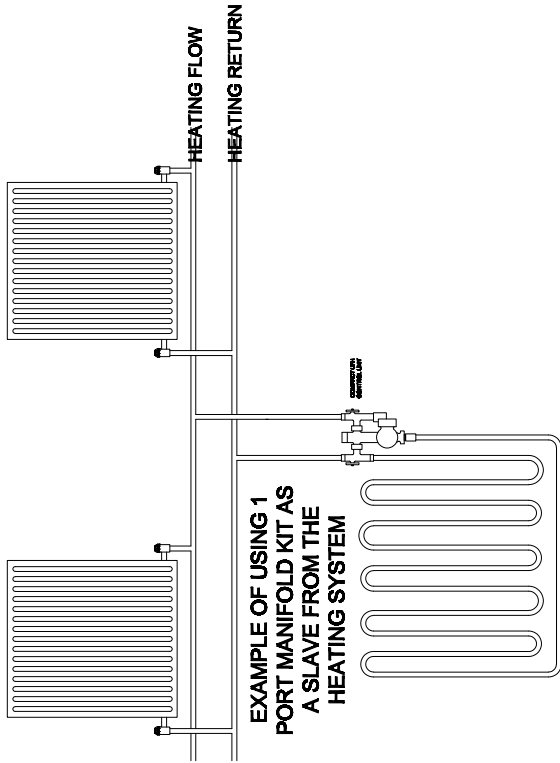

The unit has a built in sensor which activates the pump once the input water temperature reaches 42°C and pumps the warm water around the circuit. There isn't any room temperature control, the overall temperature can be altered with the blending valve on the unit.

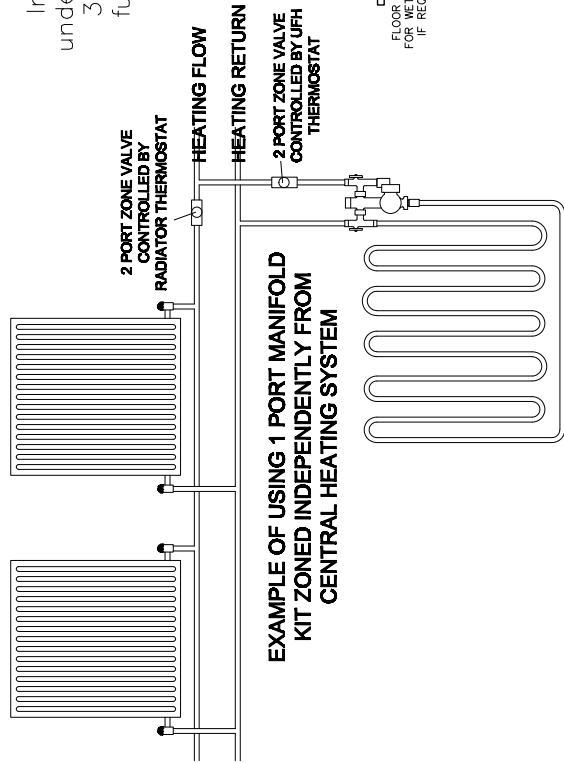
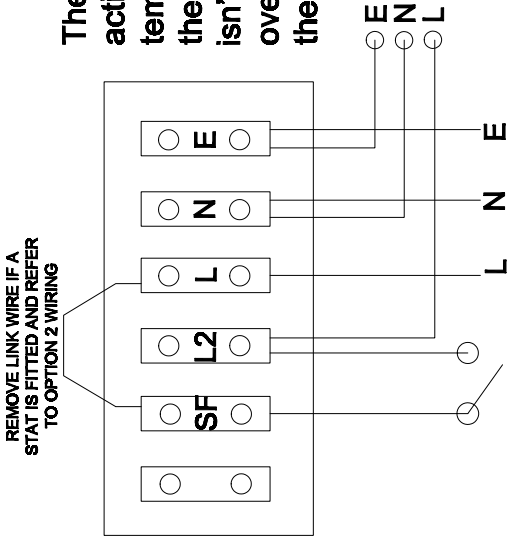

In order to isolate underfloor controls fit a 3 amp double pole fused spur to each manifold

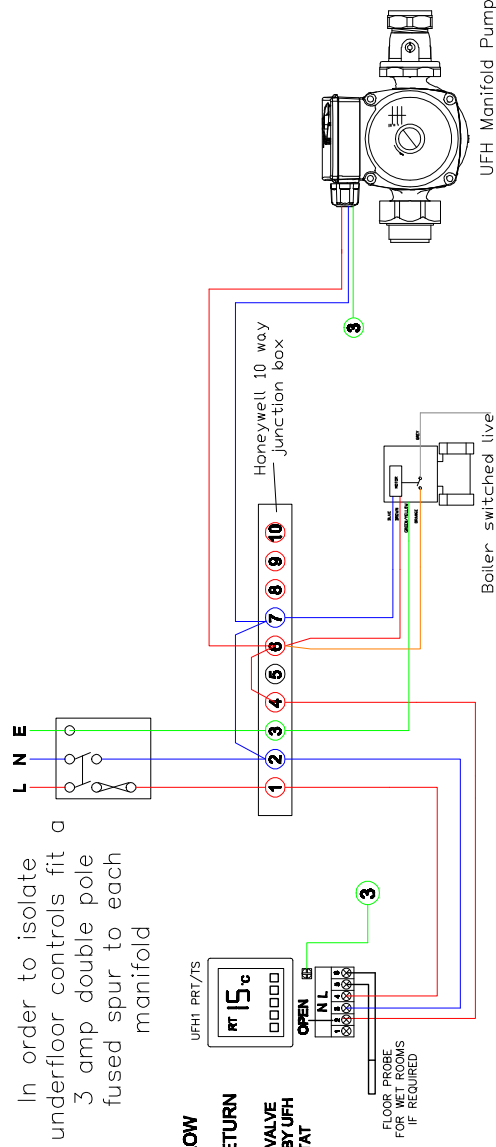

OPTION 2

Underfloor heating electrical schematic

UFH1 PRT/PRT-TS
with actuators and Toplo
wiring centre

THIS IS ONLY A PROPOSED ELECTRICAL SCHEMATIC AND DOES NOT NECESSARILY SHOW ALL REQUIRED COMPONENTS.
THIS SHOULD ALWAYS BE INSTALLED BY A QUALIFIED ELECTRICIAN.

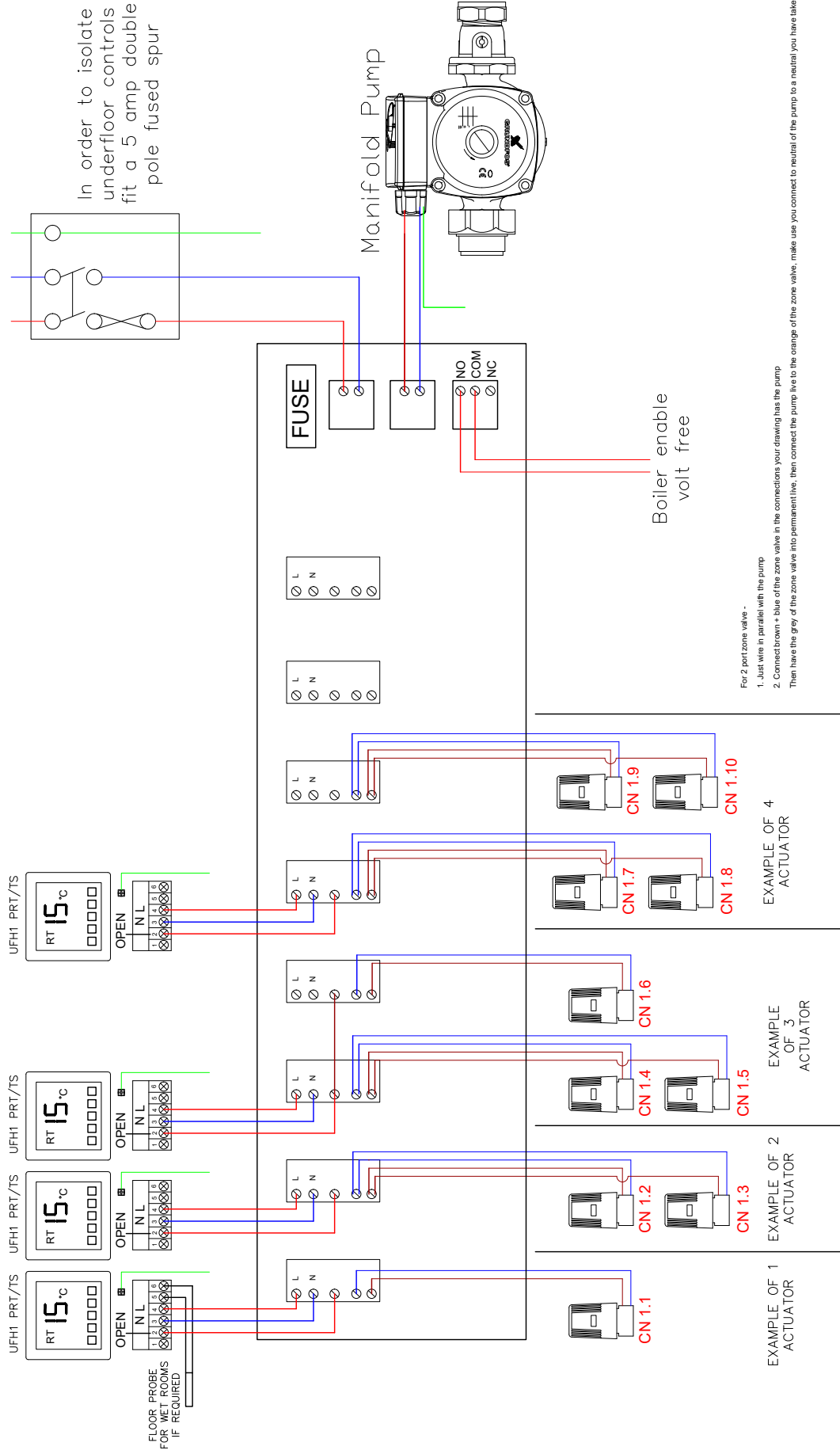



Function Definitions

WW: Water Heating (3A)

WE: Electric Heating (16A)

WW-LD: Water Heating with Wall-hung Boiler Interlock

Product Features

- ✧ Standard 86x86mm size, suitable for various installation scenarios, compatible with European standard junction boxes.
- ✧ Multiple color options available
- ✧ Wall-mounted steel plate design for simple and quick installation.
- ✧ Built-in and external temperature sensor support for safer and more comfortable use.
- ✧ High control accuracy of up to $\pm 0.5^{\circ}\text{C}$, precisely maintaining your set temperature
- ✧ Child Lock function to prevent accidental operation by children
- ✧ Power-off memory function; automatically resumes previous settings after power restoration for user convenience.
- ✧ Rich programming modes, including 5+2, 6+1, and 7-day cycle modes, supporting user customization.
- ✧ Classic Holiday Mode for automatic energy-saving operation during vacations.
- ✧ External sensor temperature can be queried via button press.
- ✧ Temporary Manual Mode: In Program Mode, manually adjusting the temperature will override the schedule until the next programmed period..

Product Specifications

- ✧ Operating Voltage: 90-240VAC, 50/60Hz
- ✧ Sensor: NTC (10K) $\pm 1\%$
- ✧ Load Current: 3A (WW); 16A (WE)
- ✧ Temperature Limit Range: $1\sim 70^{\circ}\text{C}$
- ✧ Preset Range: $5\sim 35^{\circ}\text{C}$
- ✧ External Sensor: Optional (NTC)
- ✧ Accuracy: $\pm 0.5^{\circ}\text{C}$
- ✧ Dimensions: $82*82*27$

Display Icon Description

 Indicates Program Mode when displayed.

 Indicates Manual Mode when displayed.

 Indicates Temporary Manual Mode when displayed

 Indicates Holiday Mode is active. Holiday days and temperature can be set; runs in countdown mode.

 Indicates heating is active; disappears when heating stops. Flashes when high-temperature protection is triggered

 Clock icon

 Room temperature value

EXT External Sensor Temperature Value

 Indicates the Child Lock is active.

 Cooling Mode, Flashing Cooling Mode Load Output

 Window opening function activated, valve forced to close.

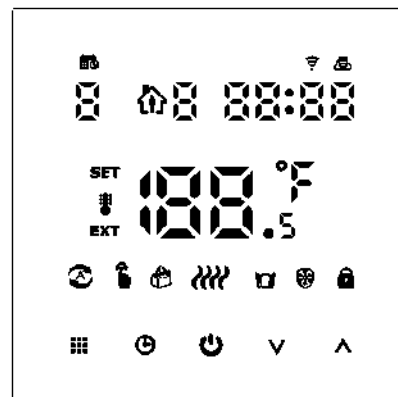

Key Function Description



◇ Power button: Short press to turn on/off



- ◇ Setup button: Short press to switch between manual mode and programming mode
- ◇ Power on, press and hold for 3-5 seconds to enter programming parameter settings.
- ◇ Power off, press and hold for 3-5 seconds to enter Advanced Option A.



- ◇ Press briefly to increase temperature
- ◇ Press and hold to check the external sensor temperature. (The N3 sensor type selection is only valid in the Advanced Options.)
- ◇ In programming mode, briefly press **▲** or **▼** to enter temporary manual mode.



- ◇ Confirmation button, short press to set clock parameters
- ◇ Power on, Press and hold for 3-5 seconds to enter holiday parameter settings. When OFF is flashing, press **▲** or **▼** to switch to ON. Press and hold briefly to set holiday days and holiday temperature., Press again to activate holiday mode.

- ◇ Power off, Press and hold for 3-5 seconds to enter Advanced Options B.



- ◇ Short press to decrease temperature
- ◇ Press and hold to lock/unlock the thermostat



Programming Mode Parameter Settings

Users can choose from six programming modes: 5+2 (default), 6+1, or 7 days (same schedule daily). Select the programming mode in the advanced options. □ Power on, press and hold for 3-5 seconds to enter programming parameter settings. After entering the settings menu, briefly press to cycle through the programming hour, programming minute, and programming period temperature settings options., Press **▲** or adjust the corresponding parameters. After completing the settings, the interface will automatically save the parameters and exit after 10 seconds.





1		2		3		4		5		6	
Get up		Leave home		Back home		Leave home		Back home		Sleep	
6:00	20°C	8:00	15°C	11:30	15°C	13:30	15°C	17:00	15°C	22:00	15°C

Advanced Option A





1、Advanced Option A

Power off , long press  for 3-5 seconds to access advanced option A. short press to choose the option, and adjust data by  or  , short press to switch next option. Remain about 10 seconds after finish setting will quit setting.

Option	Setting Item	Setting Parameters	Factory Default
A1	Measurement Temperature Calibration	-9~+9°C (Displays the corrected room temperature value)	-1
A2	Startup Temperature Difference Setting	0.5~2.5°C	1°C
A3	Child Lock Setting	0: Semi-lock 1: Full lock	0
A4	Power-on Status	0: Power-on status is the same as before power-off 1: Power-on status is OFF 2: Power-on status is ON	0
A5	Thermostat Standby Brightness	0: Off 1: Dim 2: Bright	2
A6	Programmable Working Mode	0: 5+2 1: 6+1 2: 7	0
A7	Lower Temperature Limit Setting	1~10°C	5
A8	Upper Temperature Limit Setting	20~70°C	35

Option	Setting Item	Setting Parameters	Factory Default
A9	Low Temperature Protection Setting	1~10°C. When set to 10°C, pressing "  " will display [--], indicating the function is disabled.	5
AA	High Temperature Protection Setting	20~70°C. When set to 20°C, pressing "  " will display [--], indicating the function is disabled.	45
AB	High Temperature Protection Hysteresis	1~9°C	2
AC	Window Opening Function Trigger Temperature	5~25°C. When set to 5°C, pressing "  " will display [--], indicating the function is disabled.	--
AD	Window Opening Function Duration	5~60 minutes	15
AE	Restore Factory Default Parameters	Displays Ao. Long press  the key until the LCD displays all segments to restore all parameters to factory defaults.	--
AF	Cooling/Heating Mode Selection	0: Heating Mode 1: Cooling Mode	

2、Advanced Option B

power off , press  and hold the button for 3-5 seconds to enter Advanced Option B settings. Press  briefly to cycle through available settings, then press  or  to adjust parameters. After completing settings, hold the screen for 10 seconds to automatically save parameters and exit.

Option	Setting Item	Setting Parameters	Factory Default
BN	Sensor Type Selection	N1: Single Built-in Sensor (High Temp. Protection Off) N2: Single External Sensor (High Temp. Protection Off) N3: Internal Control, External Limit (If the external sensor temperature exceeds the protection value, the thermostat will forcibly shut off the load)	N1
BC	Descaling Function	0: Off 1: On	0
Bo	Product Information	Cannot be changed	

Hysteresis Explanation: The factory default high-temperature protection is set to 45°C, with a hysteresis of 2°C. When the temperature detected by the external sensor rises

Wiring Diagram

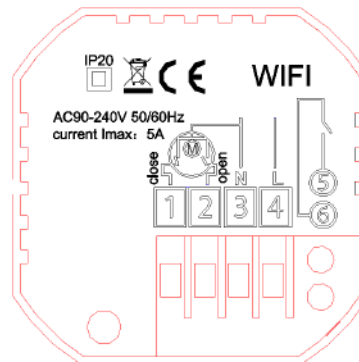
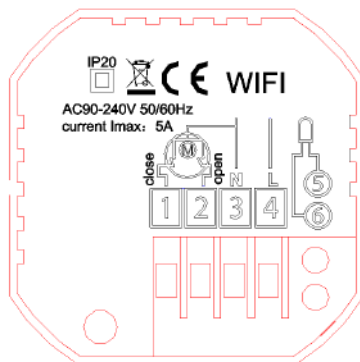
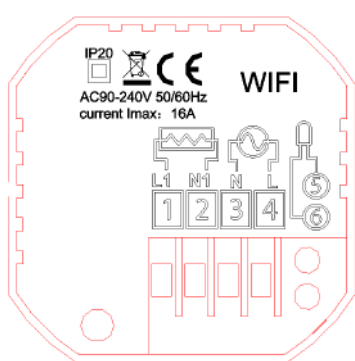

WE:Electric heating

WW:Water heating

WW-LD: Interlocking Wall-Mounted Boiler

NTC : optional (WE/WW)

Note: The wiring diagram is for reference only. For specific wiring, please refer to the actual wiring diagram provided with the product.

Product Installation Diagram

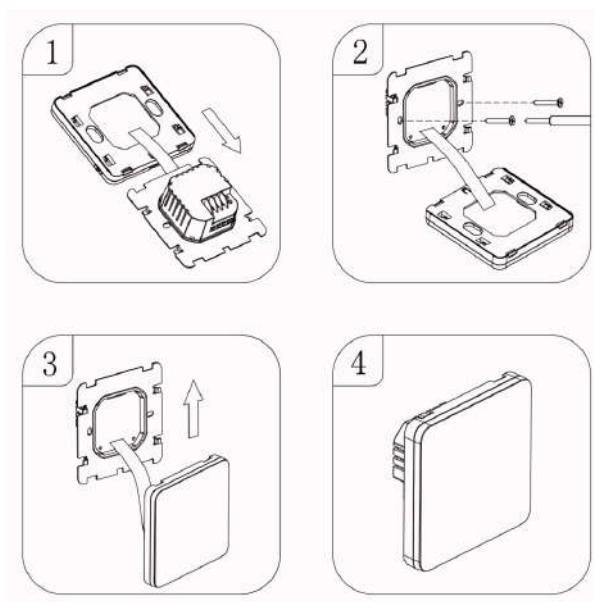

TOPLO Wifi Stat Mobile App Programming Guide

Preparation required for Wifi Connection:

You will need a 4G mobile phone and wireless router. Connect the wireless router to the mobile phone and record the WIFI password [you will need it when the thermostat is paired with the Wifi].

Step 1 Download your app



Android users can search "Smart life" on Google Play, iPhone users can search "Smart life" in the App Store.

Step 2 Register your account

- After installing the app, click "register" (Fig 2-1)
- Please read the Privacy Policy and press Agree to proceed to the next step. (Fig 2-2)
- Registration account name uses your Email Or mobile phone number. Select Region, then click "Continue"(Fig 2-3)
- You will receive a 6-digit verification code via email or SMS to enter your phone (Fig 2-4)
- Please set the password, Password must contain 6-20 letters and numbers. click "Done"(Fig 2-5)

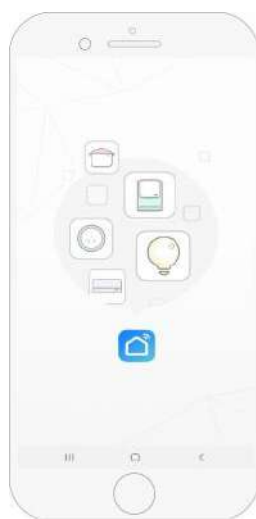

Fig 2-1



Fig 2-2

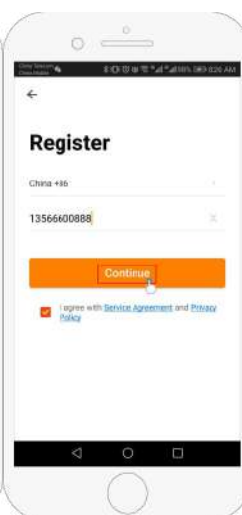

Fig 2-3



Fig 2-4





Fig 2-5

Step 3 Create family information(Fig 3-1)

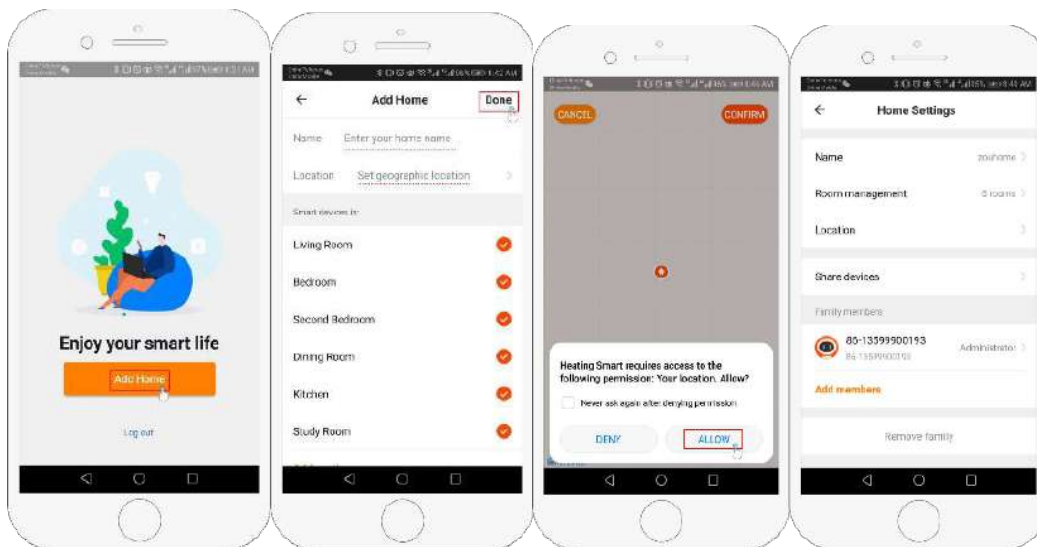
1. Fill in the family name (Fig 3-2).
2. Select or add a room (Fig 3-2).
3. Set location permission (Fig 3-3) then set thermostat location (Fig 3-4)



Step 4a Connect your Wi-Fi signal (EZ distribution mode)

1. Go to your Wifi setting on your phone and make sure you are connected via 2.4g and not 5g. most modern routers have 2.4g & 5g connection. 5g connections **do not work** with the thermostat.
2. On the phone press "Add Device" or "+" in the upper right corner of the app to add the device (Fig 4-1) and under the small appliance section select the device type "Thermostat" (Fig 4-2)
3. With the thermostat powered on, press and hold  at the same until both icons() flash to indicate the EZ distribution mode. This can take between 5-20 seconds.
4. On your thermostat confirm  icons are rapidly blinking and then go back and confirm this on your app. Enter the password of your wireless router this is case sensitive (fig 4-4) and confirm. The app will connect automatically (Fig 4-5) This may typically take up to 5~90 seconds to complete.

If you get an error message make sure you have entered your correct Wi-Fi password (case sensitive typically found on the bottom of your router) and that you are not on your Wi-Fi's 5G connection.

Your room name can be edited when the device is connected,

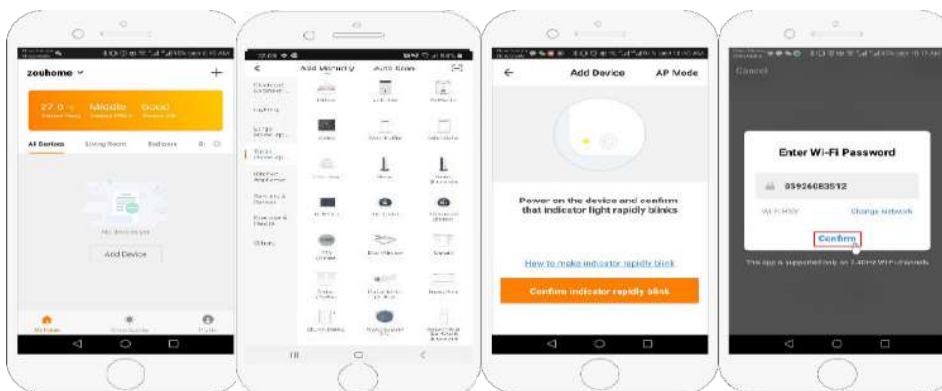

Fig 4-1

Fig 4-2

Fig 4-3

Fig 4-4

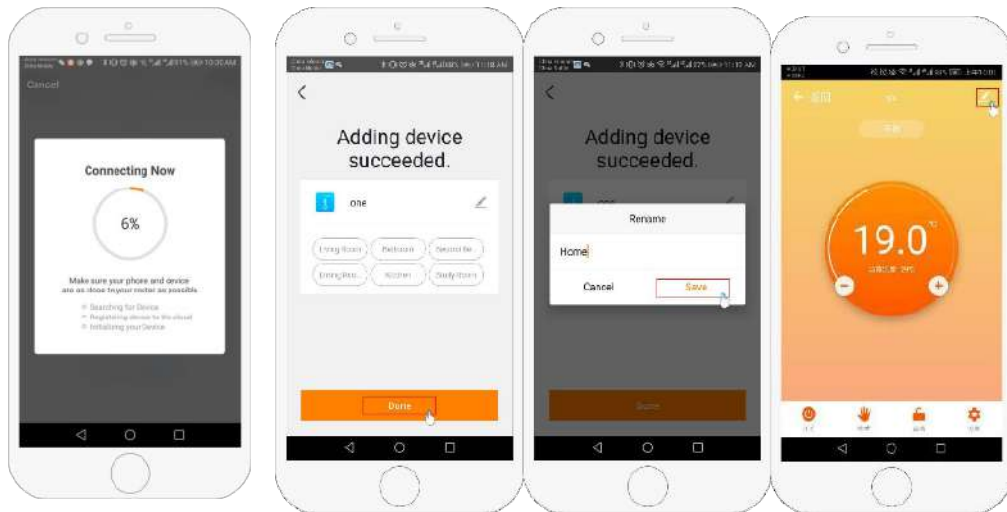

Fig 4-5

Fig 4-6

Fig 4-7

Fig 4-8

Step 4b (Alternative method) (AP mode pairing) Only do this if step 4a failed to pair the device

1. On the phone press "Add Device" or "+" in the upper right corner of the app to add the device (Fig 4-1) and under the small appliance section select the device type "Thermostat" and click AP Mode in the top right corner. (Fig5-1)
2. On the thermostat press power on and then press and hold **SET** and **OK** until flashes. This can take between 5-20 seconds. If also flashes release buttons and press and hold **SET** and **OK** again until just flashes.
3. On the app click "confirm light is blinking", then enter the password of your wireless router (fig 4-4)
4. Press "Connect now" and select the Wifi signal (Smartlife-XXXX) of your thermostat (Fig 5-3 and 5-4) it will say internet may not be available and ask you to change network but ignore this.
5. Go back to your app and click "Connect" then the app will connect automatically (Fig 4-5)

This may typically take up to 5~90 seconds to complete and will then show confirmation (Fig 4-6) and allow you to change the thermostat name (Fig 4-7)

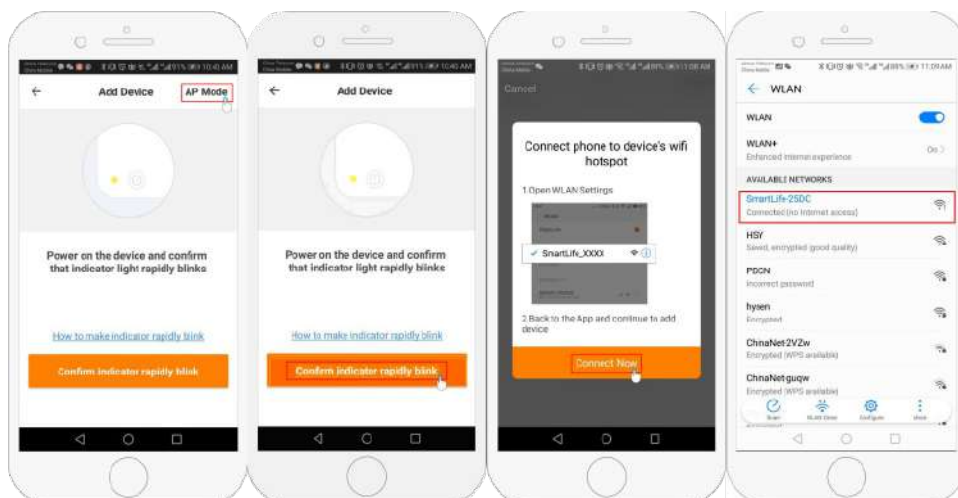

Fig 5-1

Fig 5-2

Fig 5-3

Fig 5-4

Step 5 Changing sensor type and temperature limit

Press the setting key  (Fig 4-8) in the bottom right hand corner to bring up the menu.

Click the Sensor type option and enter password (normally 123456). Then you will be given 3 options:

- (1) "Single built-in sensor" will only use the internal air sensor (DO NOT USE THIS SETTING*)
 - (2) "Single external sensor" will only use the floor probe (ideal for bathrooms where thermostat installed outside room).
 - (3) "Internal and external sensors" will use both sensors to read the temperature (Most common option).
- Once you have chosen the sensor type, check that "Set temp. max" option is set to a suitable temperature for your flooring (typically 27°C)

*A floor probe must always be used with electric underfloor heating to protect the flooring.

Step 6 Programming daily schedule

Press the setting key  (fig 4-8) in the bottom right hand corner to bring up the menu, at the bottom of the menu there will be 2 stand alone options called "week program type" and "weekly program setting".

"Week program" type allows you to choose the number of days the schedule applies to between 5+2 (weekday+weekend) 6+1 (Mon-Sat+Sun) or 7 days (all week).



"Weekly program" setting allows you to choose the time and temperature of your daily schedule at varying points. You will have 6 options of times and temperatures to set. See example below.

Part 1	Part 2	Part 3	Part 4	Part 5	Part 6
Wake up	Leave Home	Back Home	Leave Home	Back Home	Sleep
06:00	08:00	11:30	13:30	17:00	22:00
20°C	15°C	20°C	15°C	20°C	15°C

If you do not need the temperature to rise and fall in the middle of the day then you can set the temperature to be the same on parts 2,3 and 4 so that it does not increase again until the time in part 5.

Additional Features

Holiday Mode: You can program the thermostat to be on for a set temperature for up to 30 days so that there is background heat in the house while you are away. This can be found under the mode  (fig 4-8) section. You have the option to set the number of days between 1-30 and a temperature up to 27°C.

Lock Mode: This option allows you to remotely lock the thermostat so no changes can be made. This can be done by clicking the  (Fig 4-8) symbol. To unlock click the  (Fig 4-8) symbol again.

Grouping devices: You can link multiple thermostats together as a group and control them all simultaneously. This can be done by clicking on the  (Fig 4-8) in the top right corner and then clicking the Create Group option. If you have multiple thermostats linked it will allow you to tick each one that you want to be in the group and once you confirm the selection you will be able to name the group.

Family Management: You can add other people to your family and allow them to control the devices you have linked. To do this you need to go back to the home page and click on the family name in the top left corner and then click on Family Management. Once you have selected the family you wish to manage there will be an option to Add Member, you will need to enter the mobile number or email address they have registered the app with to send them an invitation. You can set whether or not they are an administrator which allows them to make changes to the device ie removing it.

FOLLOW US ON



Search Underfloor Heating 1



Search Underfloor Heating 1



Search Underfloor Heating 1

GET IN TOUCH

Tel: 01302 727 182

Email: Sales@underfloorheating1.co.uk

Web: www.underfloorheating1.co.uk

Unit 11E, Carcroft Enterprise Park, Carcroft, Doncaster, DN6 8DD